

Verification Report

THEME [JTI-CS-2011-1-SGO-02-026]



Grant Agreement number: 296369

Project acronym: MoMoLib

Project title: Modelica Model Library Development for Media, Magnetic Systems and Wavelets

Funding scheme: Article 171 of the Treaty

Introduction

This media library is written in the Modelica language 3.2 and was developed using Dymola as an IDE. All components are guaranteed to work with Dymola 2013.

Objectives

The media library for tetrafluoroethane and humid air will provide all functions specified by the corresponding media interfaces (Modelica.Media.Interfaces.PartialTwoPhaseMedium) and media model (moist air), respectively. The implementation will be validated comparatively against software (e.g. RefProp for R134a and LibHuAir for MoistAir). The software will be provided under the Modelica License 2.0.

Status of Library

Overview

The implementation of all required functions for R134a and moist air is completed. As a byproduct the library also contains a medium model for (dry) air, which can be used as a standalone medium in simulations.

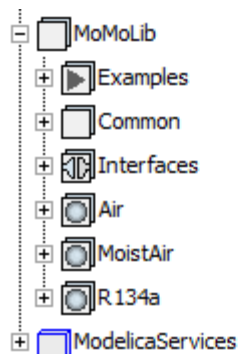

Figure 1: Structure of library

The structure of the library is shown in Figure 1. It contains an *Examples* package, where some simple examples for using the different media models are shown. The *Common* package contains some records and functions, which were used throughout the library.

The *Interface* package defines a new interface for media models, which consists of a condensing and a non-condensing gas (e.g. water and dry air). The interface Modelica.Media.Interfaces.PartialCondensingGases is inappropriate for our purposes, since it assumes the ideal gas law for the individual gases. In contrast, we treat moist air as an ideal mixture of real gases. The new interface is named PartialRealCondensingGases.

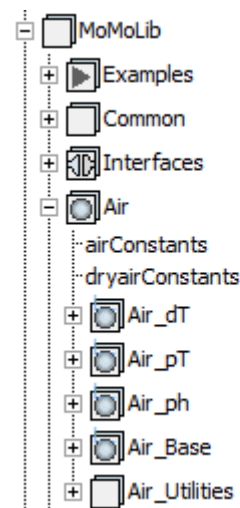

Figure 2: Medium package Air

The structure of the package *Air* (see Figure 2) is modeled along the same lines as the package Modelica.Media.Water. This helps the user to easily use the new media library without any modifications in his models. The sub package *Air_Base* contains all property functions for air. These property functions are implemented in the sub package *Air_Uilities*. To use the new air medium model, the user just has to decide, if he wants as input parameters density/temperature (dT), pressure/temperature (pT) or pressure/enthalpy (ph). Depending on this choice, one uses *Air_dT*, *Air_pT* or *Air_ph* respectively.

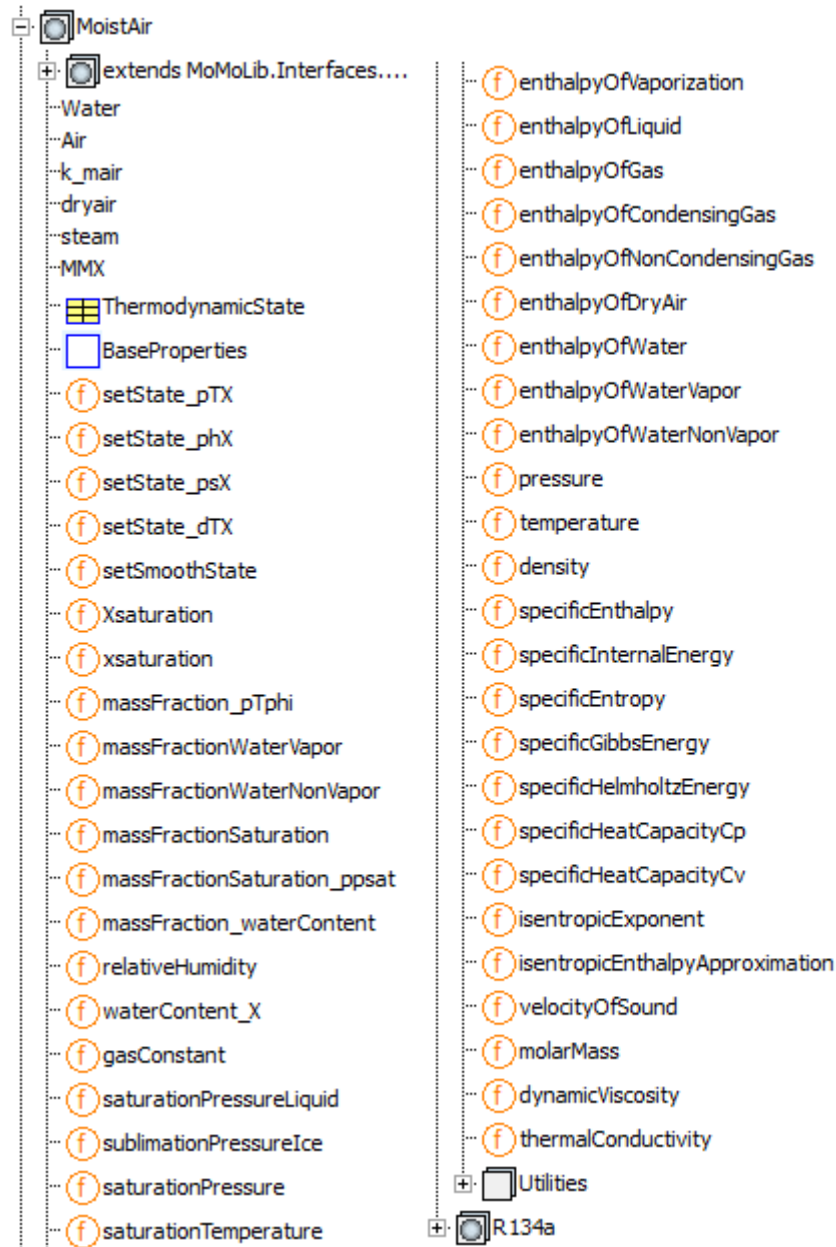

Figure 3: Content of package *MoistAir*

Task 4.2

The *MoistAir* package (see Figure 3) implements the interface *PartialRealCondensingGases*, which is an adjustment and extension of the interface *PartialCondensingGases* as explained above. For ease of use, we followed the convention that each function like *massFraction* or *specificEnthalpy* requires as input a variable of type *ThermodynamicState*, while functions as *setState_pTX* or

massFractionSaturation_ppsat require as input p , T and X or p and $psat$, respectively. Like in the package Air, there is also a Utilities sub package, which contains the actual implementations.

Task 4.1

The last package in this library contains a model of R134a. The medium model is explicit in pressure and enthalpy. The user has just to select R134a_ph in his models. This package consists of three sub packages, which provide helper routines and are self-explanatory by just looking at their names.

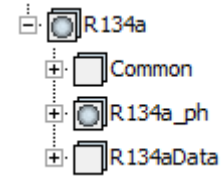

Figure 4: Structure of package R134a

Task 4.3

The MoistAir implementation was validated comparatively against the LibHuAir package, which is commercially available from the University Zittau/Görlitz.

Results

- The media library for 134a is fully implemented according to the requirements of the corresponding media interface
- A new media interface was developed for ideal mixtures of real condensing gases
- The media library for moist air is fully implemented according to the new media interface
- As a byproduct there is also a new media library for dry air
- The implementation of R134a was validated against RefProp
- The implementation of moist air was validated against LibHuAir
- The implementations of R134a and MoistAir were verified by different test models

Project Management

There have been hold 2 telephone conferences with Michael Sielemann from DLR on the progress of the work:

1. Conference on 2012/03/07
2. Conference on 2012/08/22

2 Verification of R134a properties

All functions which have been provided were checked with a number of test models:

- Model 1: a generic test model to evaluate all functions for a map of pressures and enthalpies (R134a_verify)
- Model 2: an example model from the Modelica.Fluid library (DrumBoiler)
- Model 3 and 4: two example models from the Modelica Media library (Modelica.Media.Examples.Tests.Components.PartialTestModel, and PartialTestModel2)
- Model 5: a complete refrigeration system modeled by an in-house library of XRG (Testcycle)

For testing purposes the Modelica Standard Library 3.2 and Dymola 2013 FD01 have been used.

Model 1 was used to check the results against NIST's RefProp data base and to create property diagrams that are supplied with the library. Furthermore, the numerical derivative functions have been checked.

logarithmic pressure grid between 1 and 104 bar. The obtained pressure and enthalpy table was further used as an input to all property functions of the library. The Dymola result was compared to the values calculated from RefProp for the following properties.

All figures that are shown display the original results of Dymola (and interpolation between the grid points).

2.1.1 Temperature

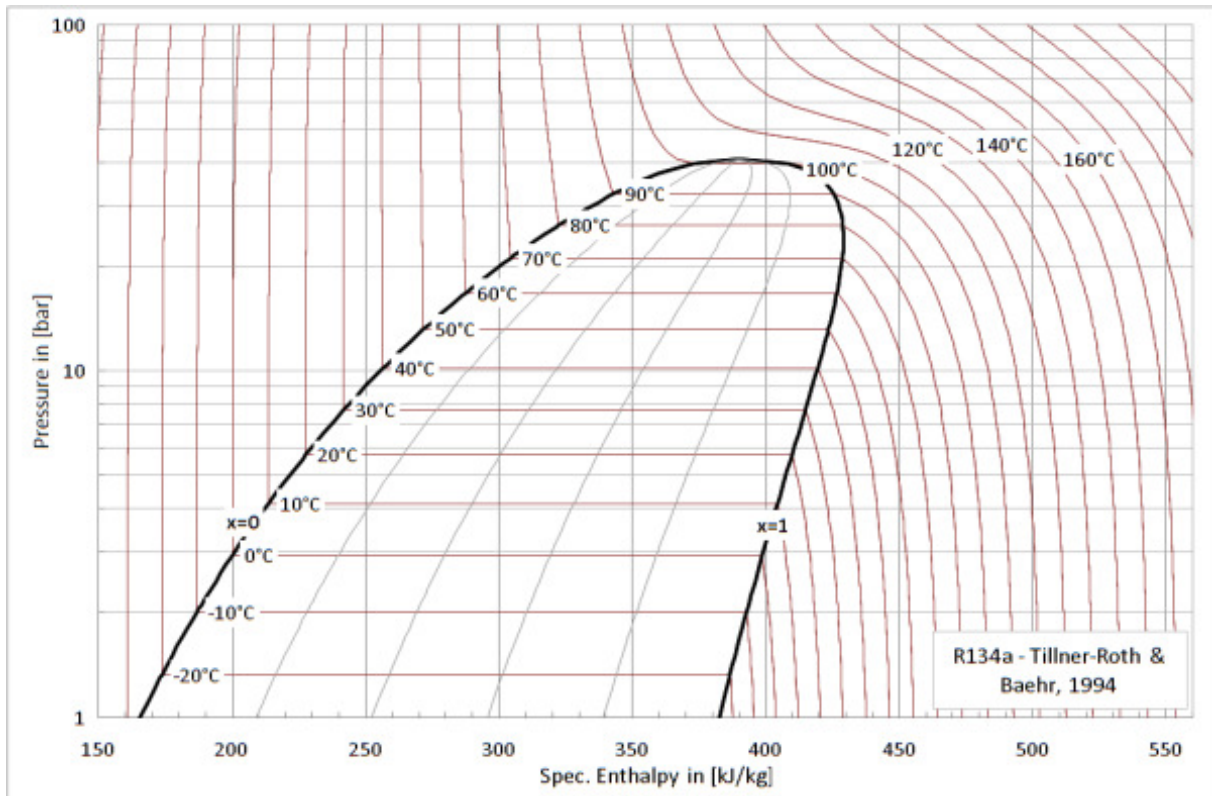

2.1.2 Density

The maximum error for the calculation of the density is 0.11% and the average error is 0.00052%.

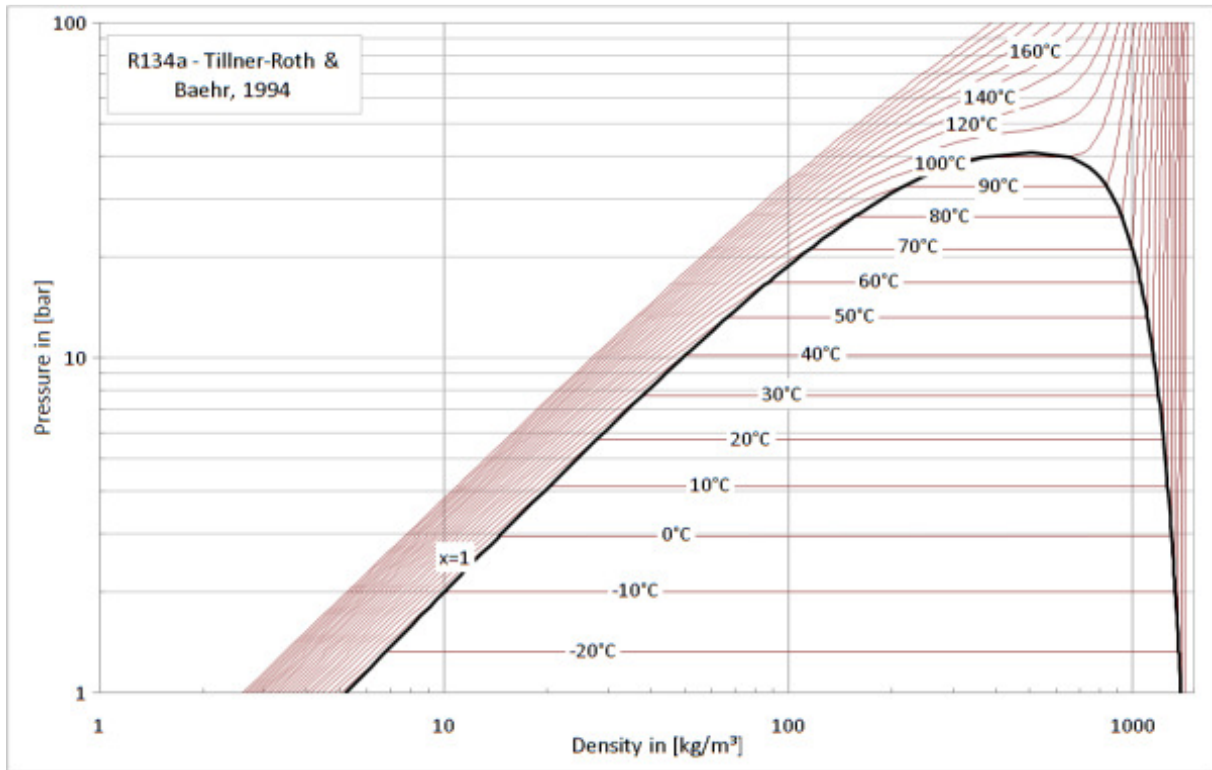

2.2.2 Specific Internal Energy

The maximum error with regard to the RefProp result is not larger than 0.0004%.

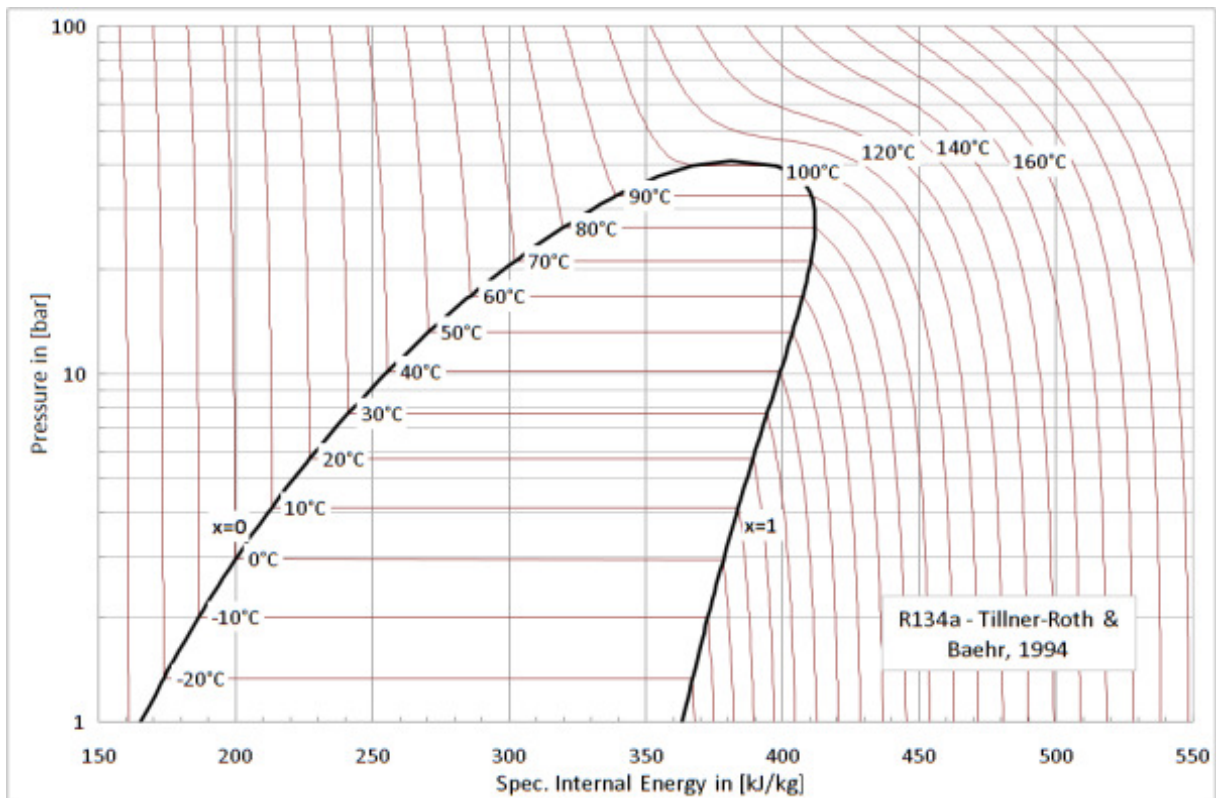

2.2.3 Specific Entropy

The maximum error with regard to the RefProp result is not larger than 0.0005%.

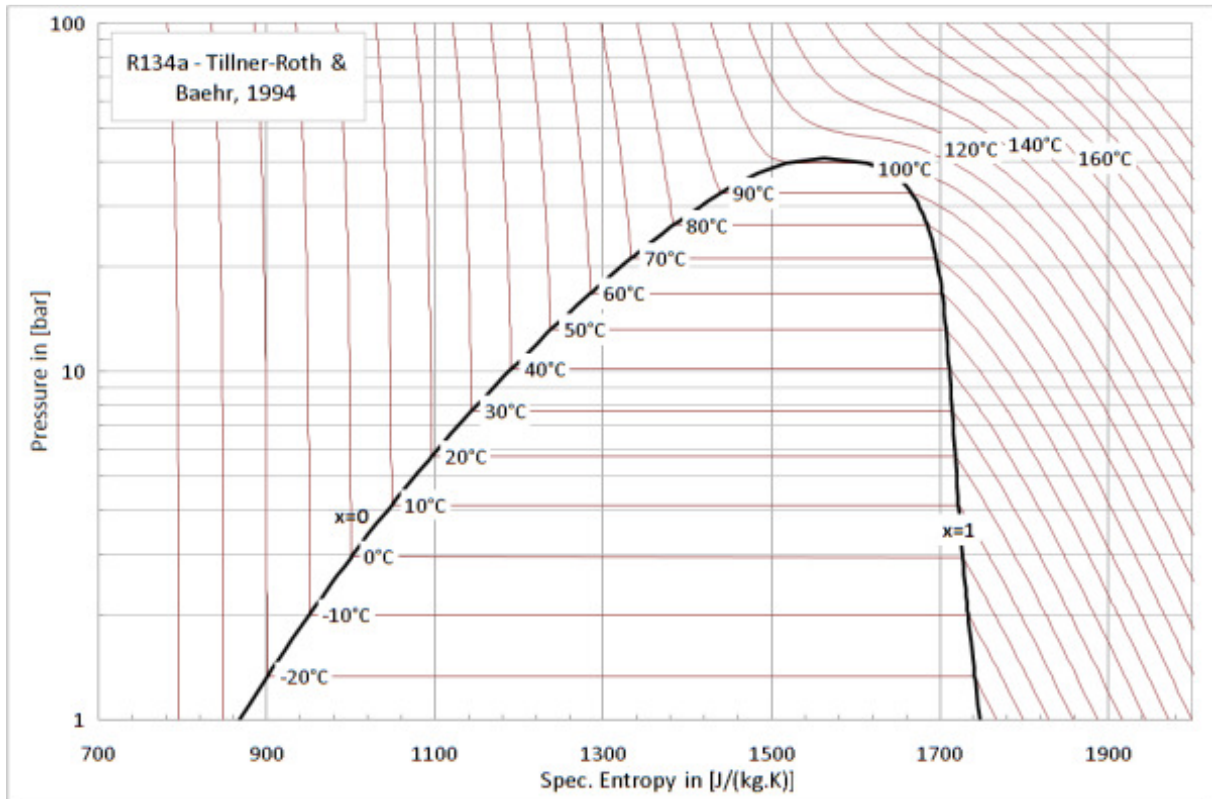

2.2.4 Specific Heat Capacity at Constant Volume

The maximum error with regard to the RefProp result is not larger than 0.027%.

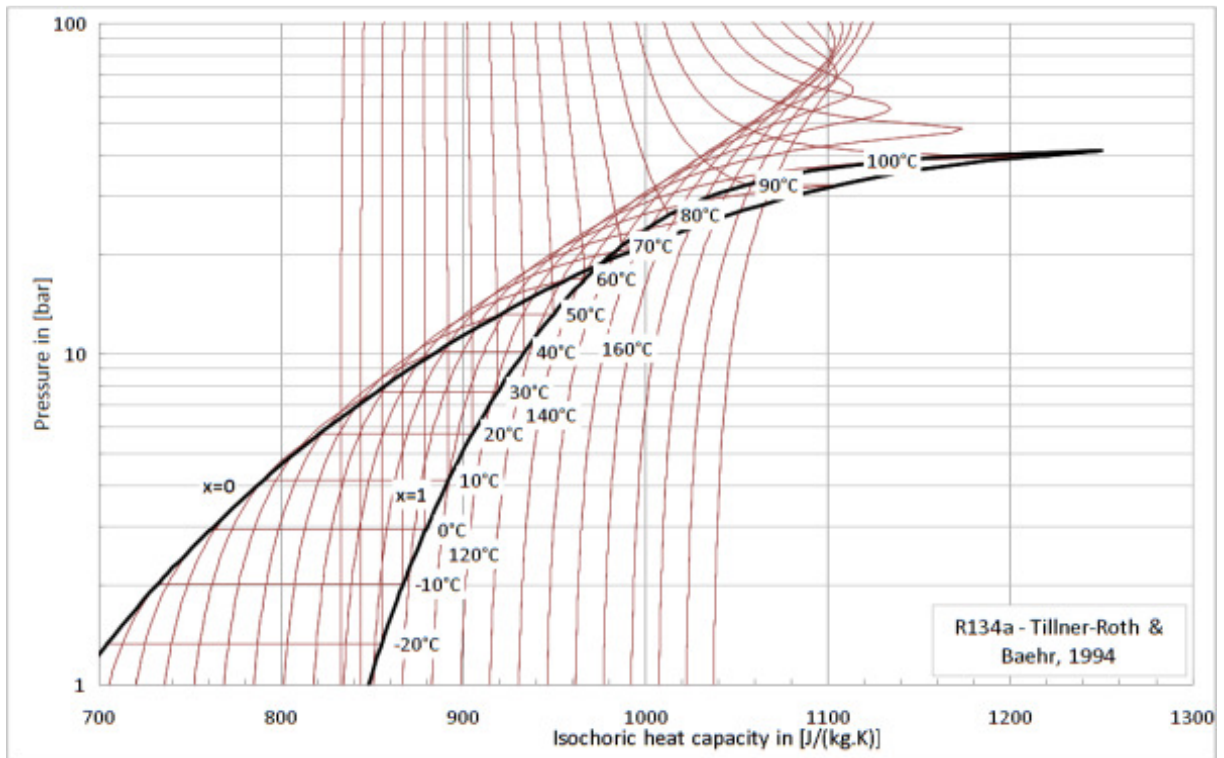

2.2.5 Specific Heat Capacity at Constant Pressure

The maximum error with regard to the RefProp result is not larger than 0.23%.

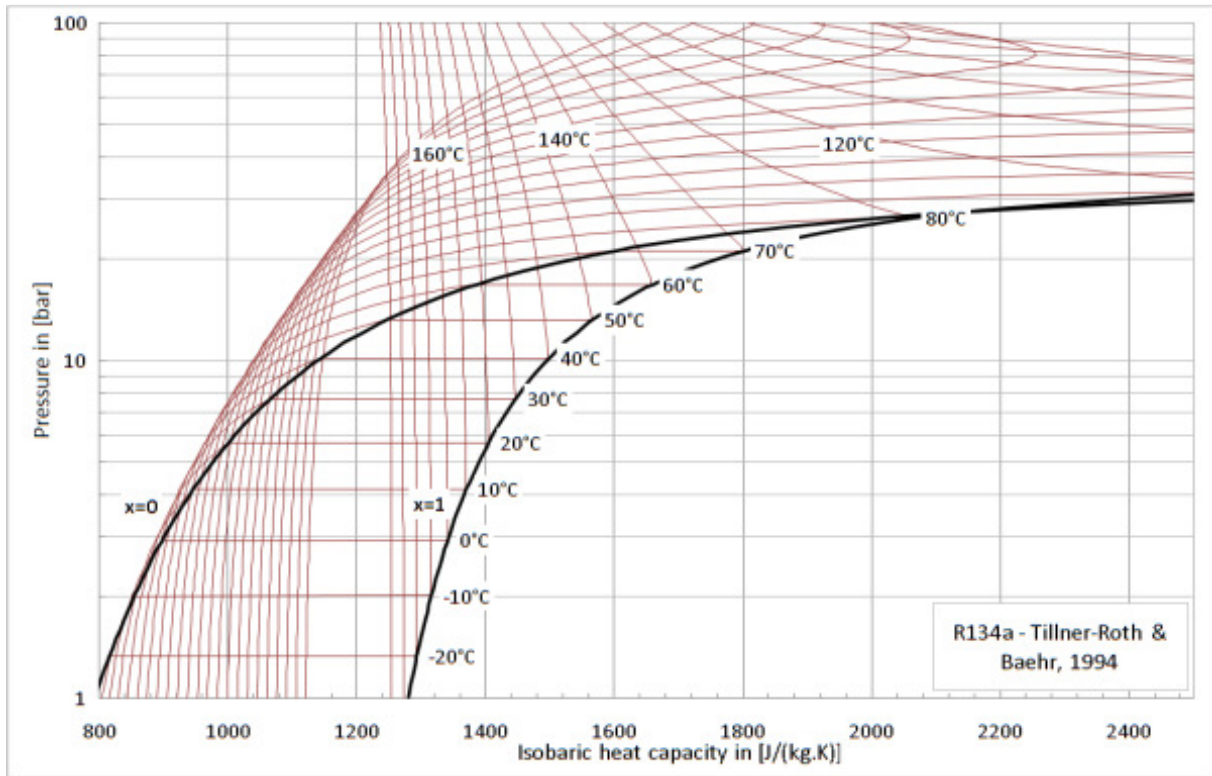

2.2.6 Velocity of Sound

The maximum error with regard to the RefProp result is not larger than 0.00042%.

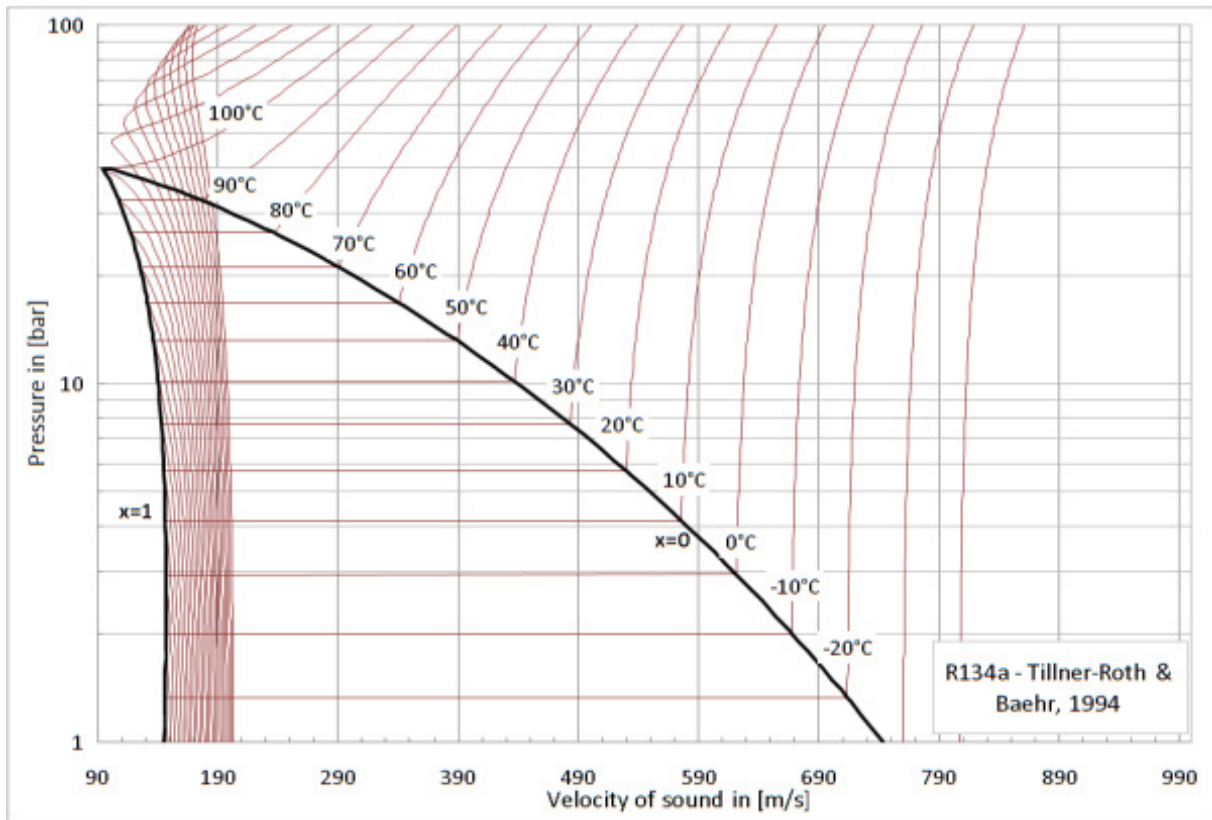

2.2.7 Dynamic Viscosity

The dynamic viscosity model of RefProp is a non-published model which varies from the version implemented in the MoMoLib Library. There are considerable deviations which are not larger than 12%.

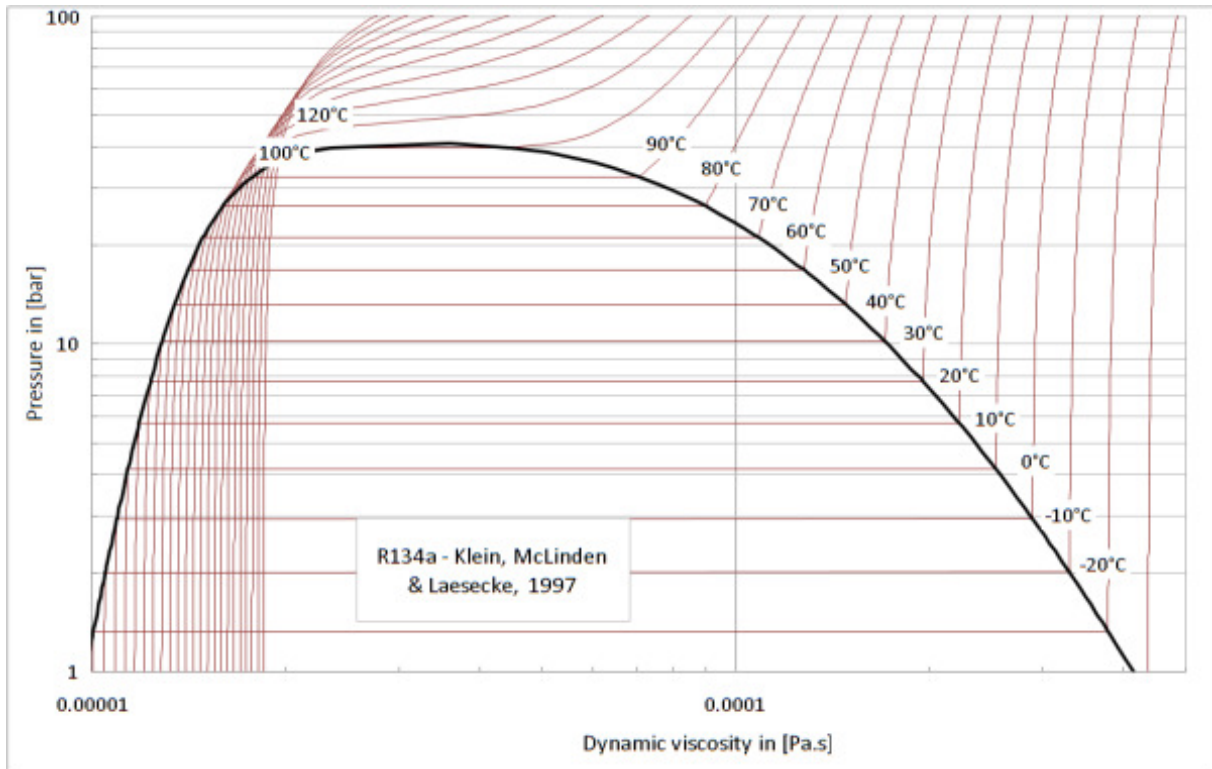

2.2.8 Thermal Conductivity

The thermal conductivity model relies in parts on the dynamic viscosity. The maximum failure is 4% with regard to the RefProp implementation.

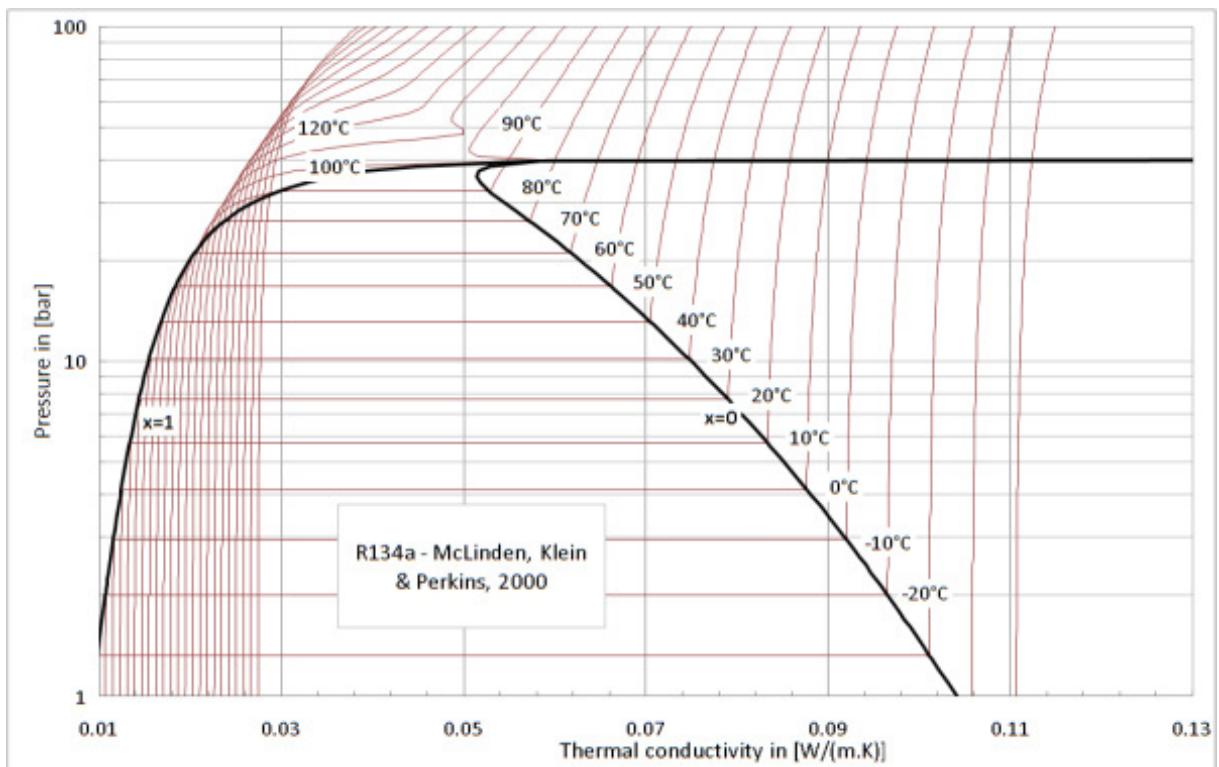

2.2.9 Surface Tension

The maximum error with regard to the RefProp result is not larger than 0.0018%.

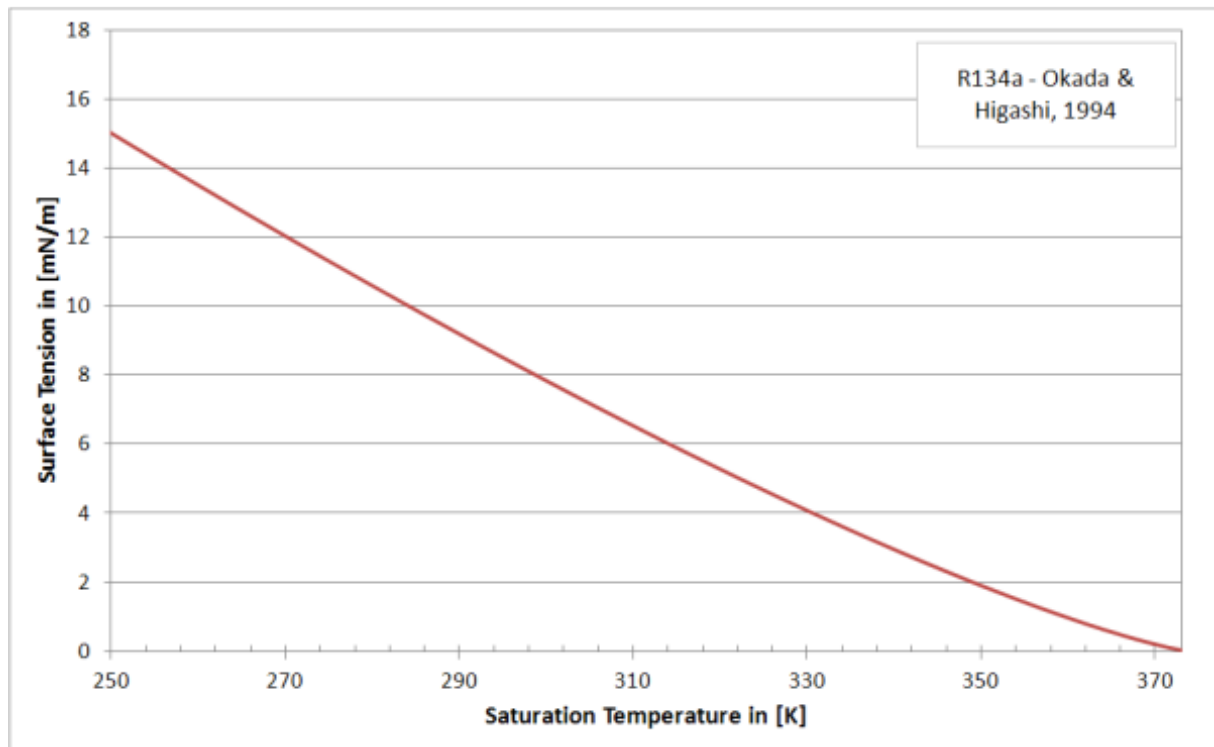

2.2.10 Saturation Pressure

The maximum error with regard to the RefProp result is not larger than 0.00015%.

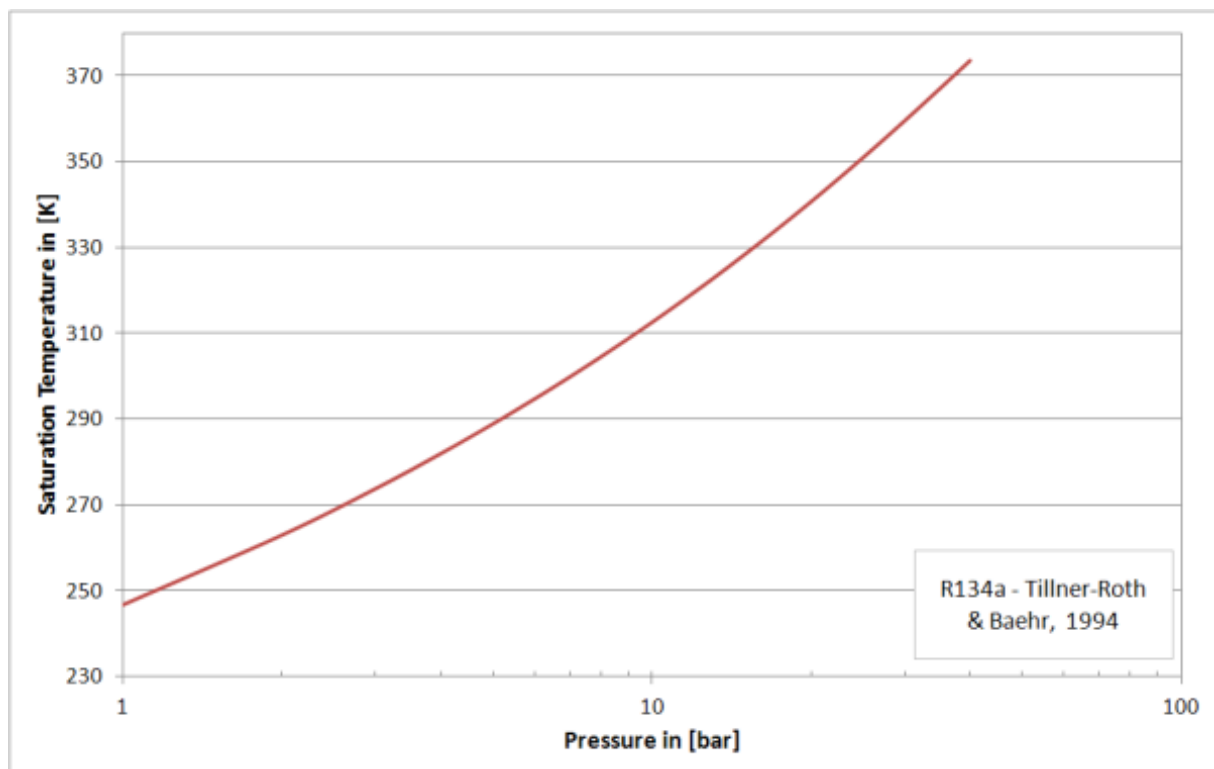

2.2.11 Isentropic Exponent

The maximum error with regard to the RefProp result is not larger than 0.005%.

2.2.12 Isothermal Compressibility

The maximum error with regard to the RefProp result is not larger than 0.005%.

2.2.13 Isobaric Expansion Coefficient

The maximum error with regard to the RefProp result is not larger than 0.005%.

2.2 Verification of R134a

2.2.1 Verification results for Model 2

The model of a drum boiler simulates a controlled kettle that is heated from outside. Originally, the model was used with water but it can also be operated with other two-phase media.

The controller shall achieve a liquid level of 50% (50m³) inside the drum. The control loop is closed by the “pump” (here: source) which feeds liquid medium into the model (h=100 kJ/kg).

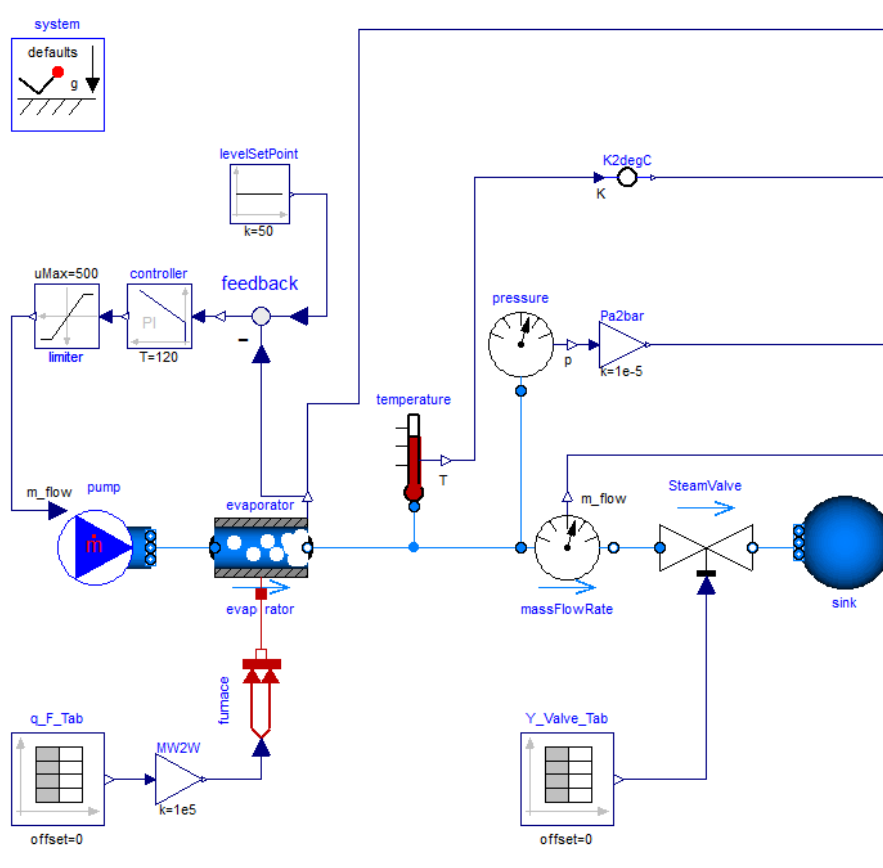

Figure 5 Diagram layer of the drum boiler model (verification model 2)

In the following three typical variables of the model are shown: the liquid volume, the steam valve inlet pressure and the vapor temperature. One can see that the control set point (50 m³) is achieved at ~4000 sec simulation time. The vapor pressure and temperature inside the drum indicate that the refrigerant remains in two-phase region.

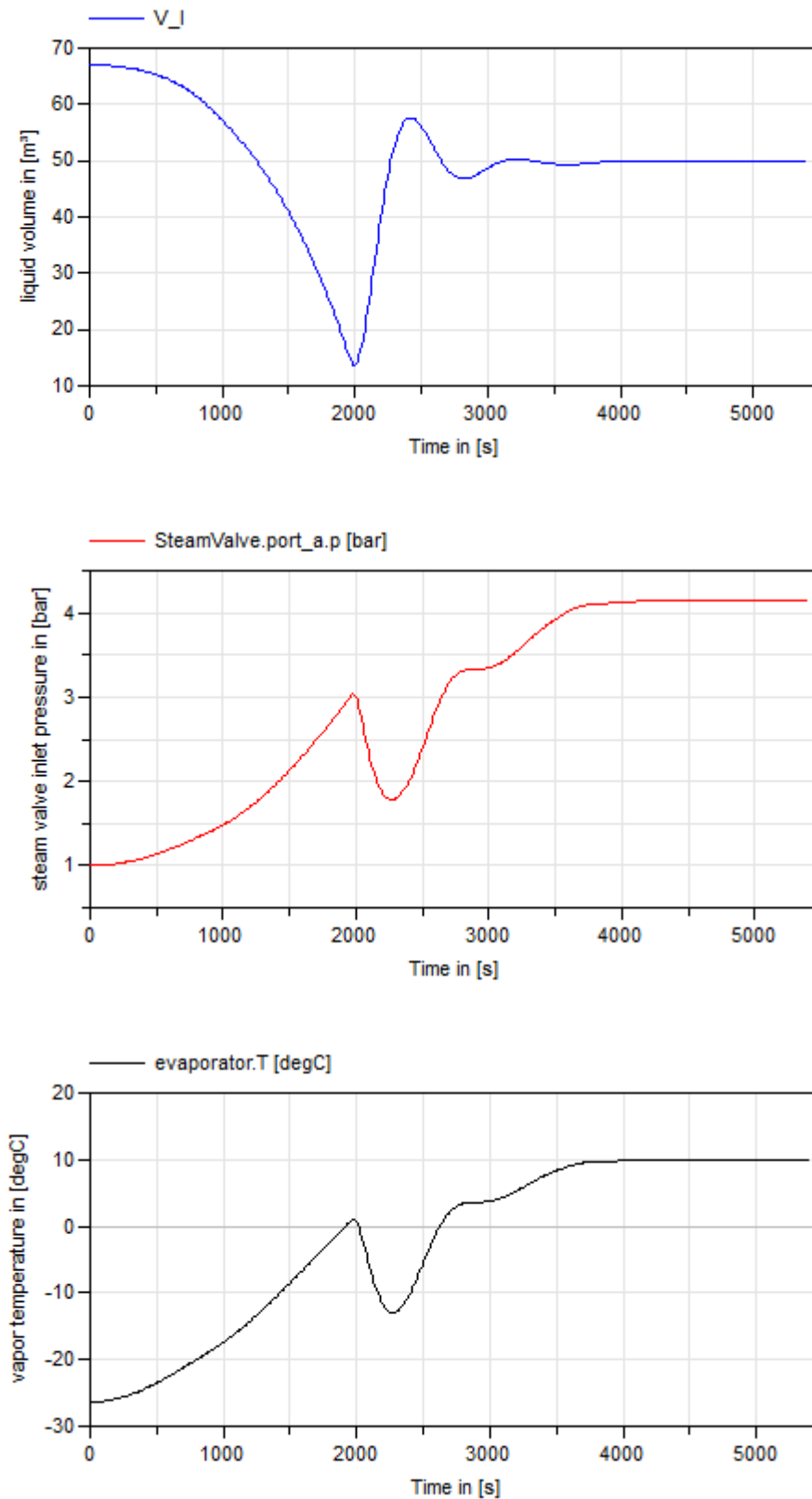

Figure 6 Model 2: liquid volume, valve inlet pressure and vapor temperature

2.2.2 Verification results for Model 3 and 4

Model 3 (see Figure 7) and 4 (see Figure 9) are test models supplied by the Modelica.Media library. Both models represent an open system with a fluid source on the left and a fluid source on the right. A volume and a flow model (pressure drop) are used to model the adiabatic pipe in between. A

transient change is induced due to the source enthalpy which is equal to that of $1.2 * T_{start}$ at a varying pressure.

Those models are non-trivial due to the default initialization with pressure and temperature and the calculation of the inlet enthalpy with variable downstream pressure and fixed temperature. This setting requires an inversion of the property function with regard to temperature, since the default states of the property model are pressure and enthalpy.

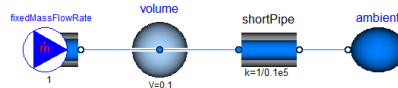

Figure 7 Model 3: PartialTestModelR134a

The results for the simulation of model 3 are shown in Figure 8 . At 0 sec the model is successfully initialized at 20 degC (default from Modelica.Media.Interfaces.PartialMedium) and 1.01325 bar.

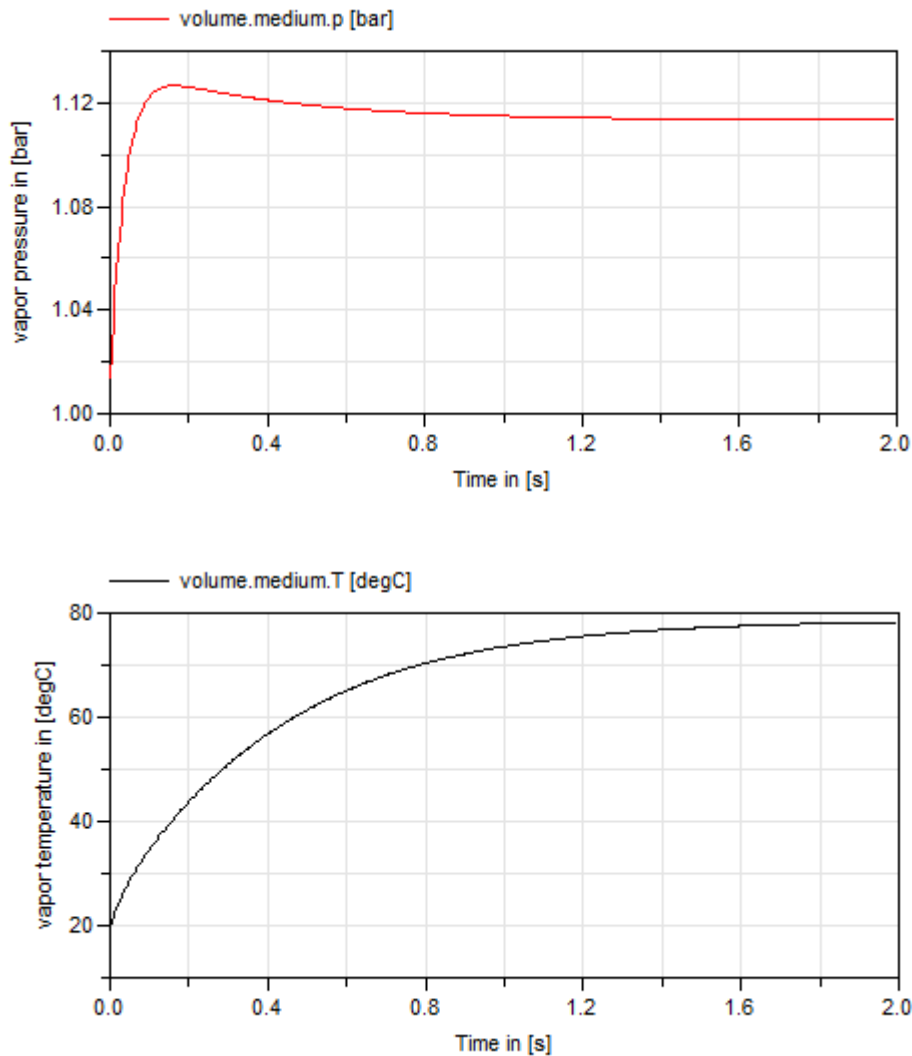

Figure 8 Model 3: volume pressure and temperature

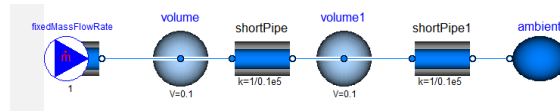

Figure 9 Model 4: PartialTestModel2R134a

In the following Figure the results for the PartialTestModel2R134a are shown. Please note, that the initialization has slightly changed according to the original model ($p_{\text{start}} = 1 \text{ bar}$, $T_{\text{start}} = 300 \text{ K}$). Again the simulation turns out successful.

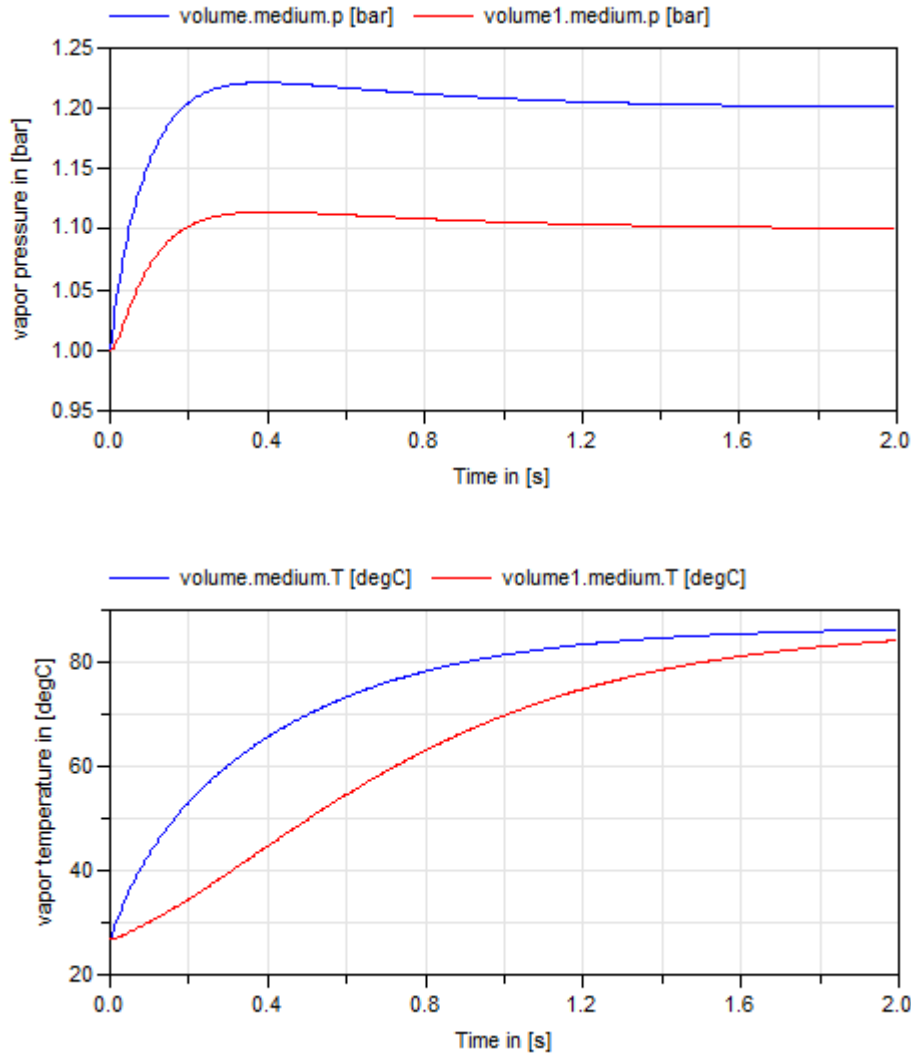

Figure 10 Model 4: pressures and temperatures within the two volumes

2.2.3 Verification for Model 5

The model consists of the following elements:

- Compressor
- Condenser
- Receiver
- Thermostatic Expansion Valve
- Evaporator
- Superheat sensor

Verification Report: Modelica Media Library

- Air side source and sink
- Coolant source and sink

Special functions and models that are used by this model are:

- Isentropic enthalpy calculation in the compressor model
- Isentropic exponent γ in the thermostatic expansion valve
- Base properties

The model has stream connectors for all types of media (one-phase and two-phase).

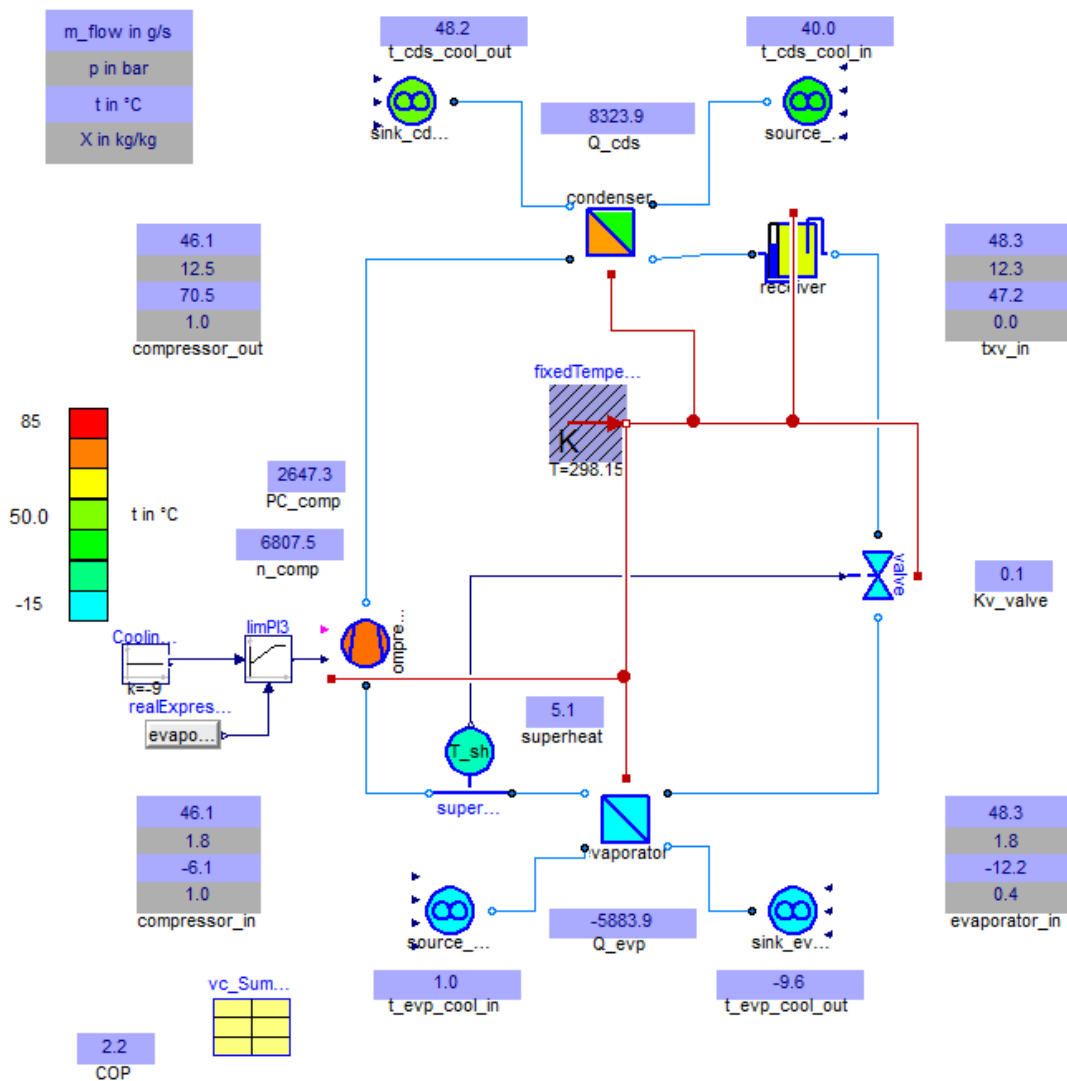

Figure 11 Model 5: transient one stage vapor compression cycle (steady-state results are shown in diagram)

Figure 11 and Figure 12 show the steady-state results of the cycle for an operation point.

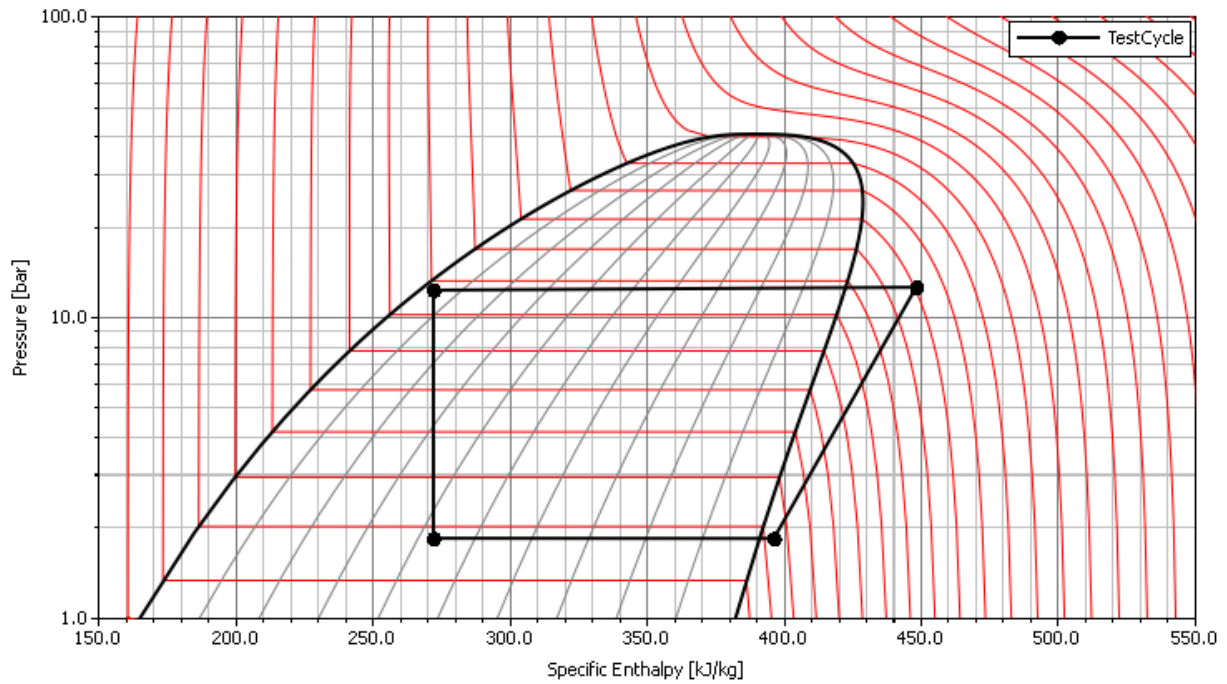

Figure 12 Model 5: Steady-State result of TestCycle

3 Verification of MoistAir package

3.1 Validation against LibHuAir

We used the commercially available package LibHuAir to validate the implementation of moist air. We scanned a range from -60 °C to 350 °C and 0.1 bar to 100 bar for the absolute humidity ratios as given in table 2. Here the unit of ξ is $\text{kg}_{\text{Water}}/\text{kg}_{\text{dry air}}$. The following tables show a summary of the maximal and average deviations of our implementation from LibHuAir.

	maximal Deviation								
ξ	0.001	0.002	0.005	0.01	0.02	0.05	0.1	0.2	0.5
cp	0.00%	0.00%	0.00%	0.00%	0.00%	0.00%	0.00%	0.00%	0.00%
d	0.00%	0.00%	0.00%	0.01%	0.03%	0.17%	0.39%	0.86%	1.48%
h	0.25%	0.31%	1.00%	-0.36%	-0.37%	-0.96%	-1.44%	-2.06%	-1.88%
s	0.00%	-0.01%	0.02%	0.07%	-0.26%	-2.87%	63.05%	-24.91%	2.76%
u	0.08%	-2.85%	-23.97%	-344.60%	-5.19%	-4.62%	-2.17%	-2.65%	-2.09%
eta	0.03%	0.06%	0.15%	0.30%	0.60%	1.45%	2.74%	4.89%	8.04%
lambda	-0.04%	-0.08%	-0.21%	-0.42%	-0.84%	1.32%	1.65%	2.80%	4.03%
psat	-3.39%	-3.39%	-3.39%	-3.39%	-3.39%	-3.39%	-3.39%	-3.39%	-3.39%
xsat	-4.83%	-4.83%	-4.83%	-4.83%	-4.83%	-4.83%	-4.83%	-4.83%	-4.83%

Table 2: maximal deviations of MoMoLib from LibHuAir

Note that psat and xsat do not depend on ξ and hence the values in each column are equal.

xi	average Deviation								
	0.001	0.002	0.005	0.01	0.02	0.05	0.1	0.2	0.5
cp	0.00%	0.00%	0.00%	0.00%	0.00%	0.00%	0.00%	0.00%	0.00%
d	0.00%	0.00%	0.00%	0.00%	0.00%	0.00%	0.00%	0.01%	0.03%
h	0.00%	0.00%	0.00%	0.00%	0.00%	-0.01%	-0.02%	-0.04%	-0.05%
s	0.00%	0.00%	0.00%	0.00%	0.00%	0.01%	0.13%	-0.12%	-0.05%
u	0.00%	-0.01%	-0.05%	-0.75%	0.00%	-0.05%	-0.06%	-0.07%	-0.07%
eta	0.02%	0.04%	0.09%	0.18%	0.34%	0.77%	1.36%	2.24%	3.15%
lambda	0.01%	0.01%	0.03%	0.07%	0.13%	0.27%	0.43%	0.64%	0.79%
psat	-0.17%	-0.17%	-0.17%	-0.17%	-0.17%	-0.17%	-0.17%	-0.17%	-0.17%
xsat	-0.25%	-0.25%	-0.25%	-0.25%	-0.25%	-0.25%	-0.25%	-0.25%	-0.25%

Table 3: average deviation of MoMoLib from LibHuAir

3.1.1 Specific isobaric heat capacity

As Table 2 shows our implementation of cp yields the same results as LibHuAir does. The maximal deviation is 0%.

3.1.2 Density

As Table 2 shows our implementation of d gives the same results as LibHuAir. For pressures lower than 20 bar the maximal deviation is less than 0.37%. Only for high pressures and very high mass fractions of water the deviation is up to 1.48% for some single states.

3.1.3 Specific enthalpy

According to Table 3 the results of MoMoLib are almost the same as those of LibHuAir. The maximal error is 2.06%.

3.1.4 Specific entropy

For most values of mass fraction of water the calculated values of s by MoMoLib are the same as those of LibHuAir. For 100 bar, 180 °C and xi=0.1 there is an error of 63.05 %. This seems to be a bug in LibHuAir and not MoMoLib. See also the next section.

3.1.5 Specific internal energy

The computed values by MoMoLib are in good accordance to LibHuAir except for 100 bar, 100 °C and xi=0.01 and 100 bar, 110 °C and xi=0.005. This is a bug in LibHuAir. The fundamental relation in thermodynamics $h = u + p/d$ holds for our implementation but for LibHuAir this relation is not valid. It must be pointed out that MoMoLib is consistent with respect to this fundamental equation, while LibHuAir does not satisfy this equation for all states.

3.1.6 Dynamic viscosity

For small values of mass fraction of water ($xi < 0.05$), the results of MoMoLib and LibHuAir differ by less than 1% at maximum. For higher mass fractions of water the error is no more than 8%.

3.1.7 Thermal conductivity

Here the same conclusion as for dynamic viscosity applies. The maximal error is at maximum less than 4%. It must be noted that MoMoLib uses the latest IAPWS formulation of 2011 for thermal conductivity while LibHuAir uses the formulation of 1985.

3.1.8 Saturation pressure

On average the error in saturation pressure calculated by MoMoLib is 0.17%. At maximum the error is less than 3.39%.

3.1.9 Saturation mass fraction

On average the error in saturation mass fraction calculated by MoMoLib is 0.25%. At maximum the error is less than 4.83%.

3.2 Test models for MoMoLib

3.2.1 Model 1

As a first test model for MoistAir we used the model Modelica.Media.Examples.MoistAir provided in the MSL. In the following two figures the green line shows the smooth state calculated from two states.

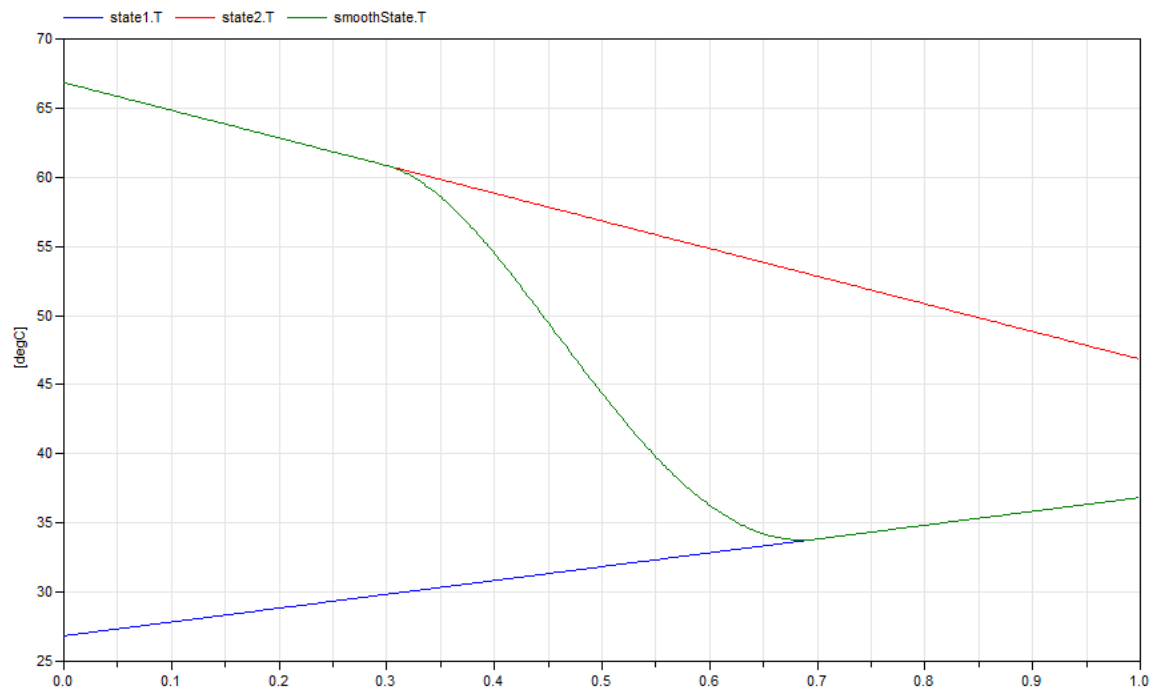

Figure 13: smoothState of temperature T

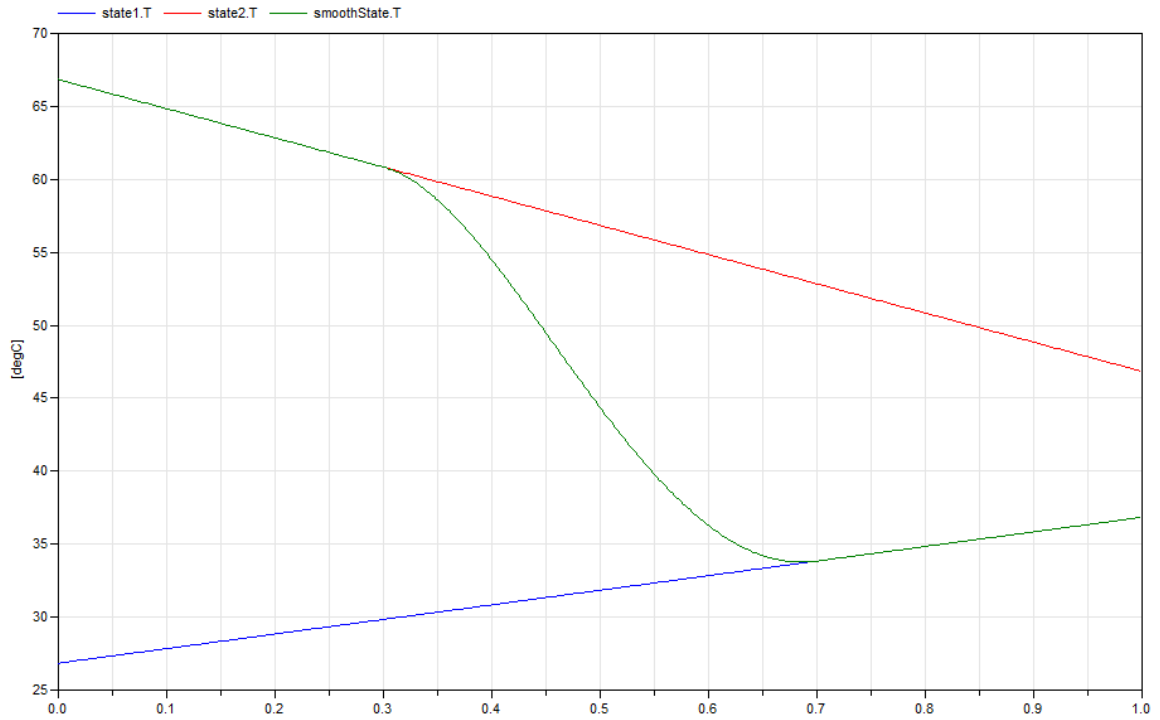

Figure 14: smoothState of pressure p

3.2.2 Model 2

The second test model is the generic test model from the Media package in the Modelica Standard Library Modelica.Media.Examples.Tests.Components.PartialTestModel (see Figure 7). The red line plots the result of MoMoLib while the blue line plots the result of the MoistAir package within the MSL. The following figures show, that the two results are in very good accordance.

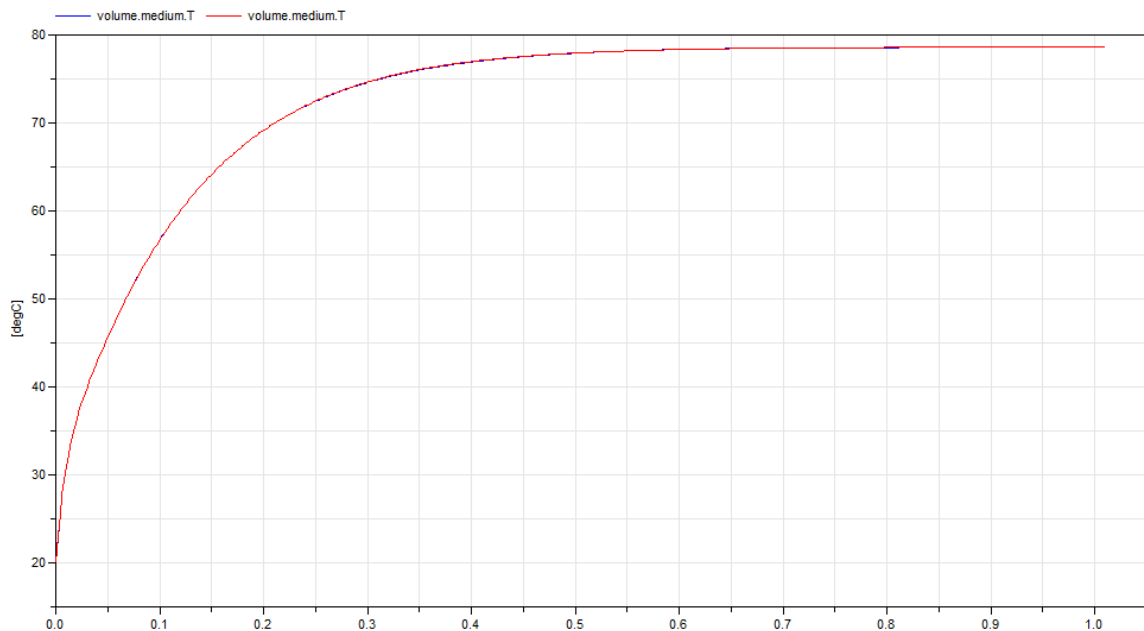

Figure 15: Results for temperature comparing MoMoLib and MSL

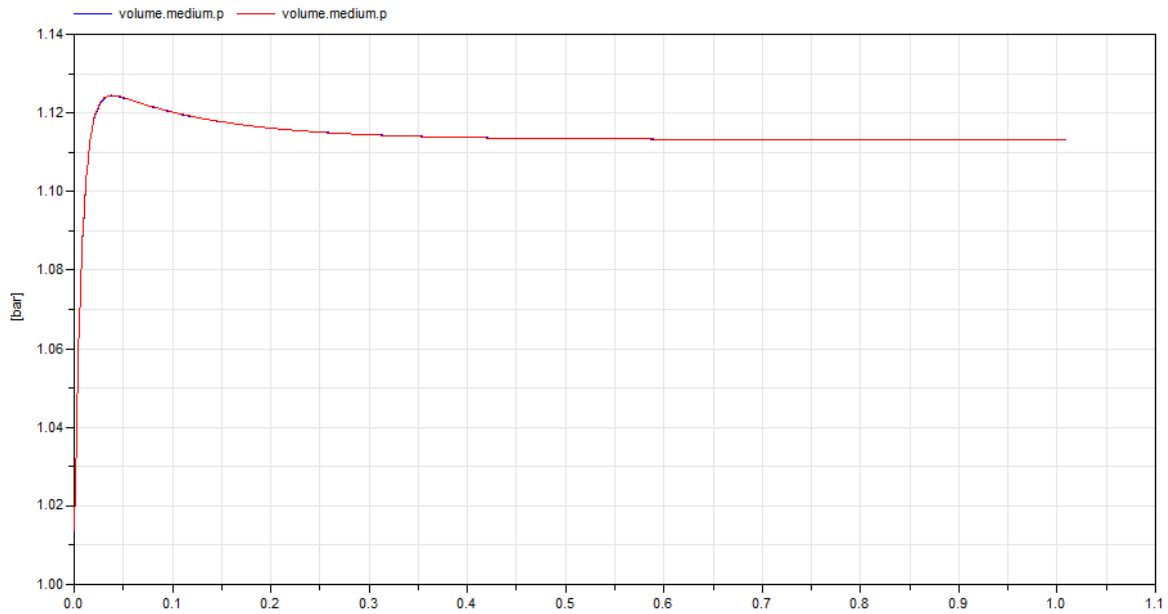
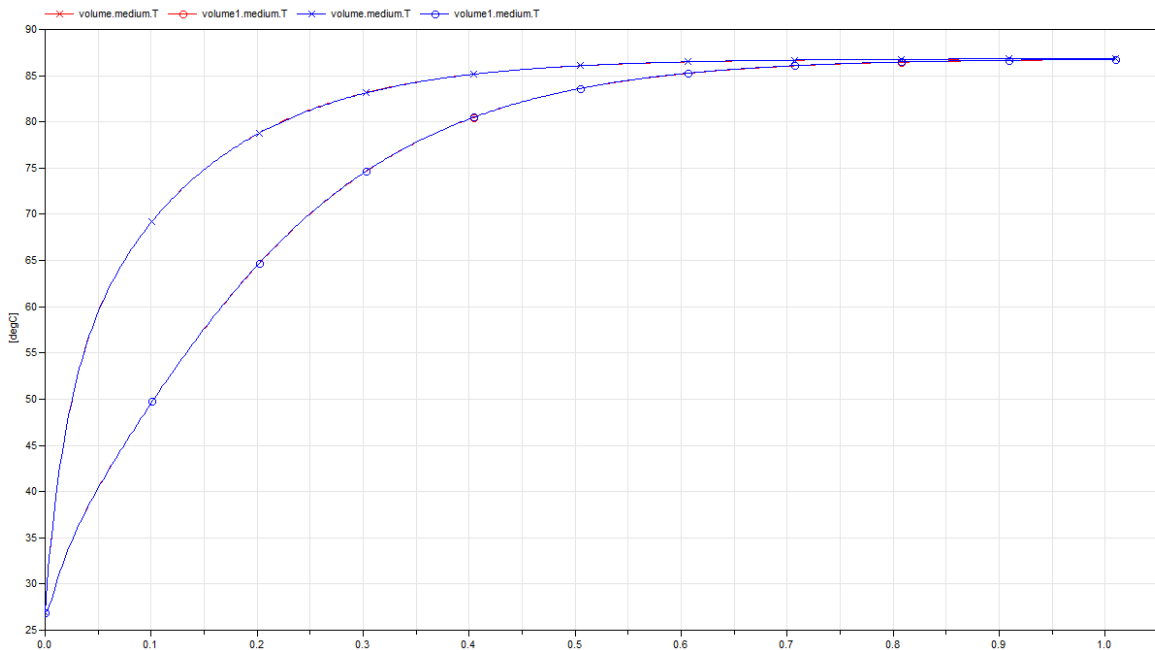

Figure 16: Results for pressure comparing MoMoLib and MSL

3.2.3 Model 3

The third model is again a generic test model from MSL, Modelica.Media.Examples.Tests.Components.PartialTestModel2 (see Figure 9). The red line in the following two figures shows the results of MoMoLib and the blue line those of MSL. The crosses and circles on the lines indicate the two different volumes in the model.



3.2.4 Model 4

The last test model is taken from the commercially available library HumanComfort of XRG Simulation. It models a building consisting of two rooms (see Figure 17). Each room has a window. One room has a window in east direction, the other in west direction. As simulation time we chose one week. The weather component of this test model is responsible to calculate the sun position. This is a quite complex model with 4613 equations. Figure 18 shows the temperature profile of the two rooms.

Verification Report: Modelica Media Library

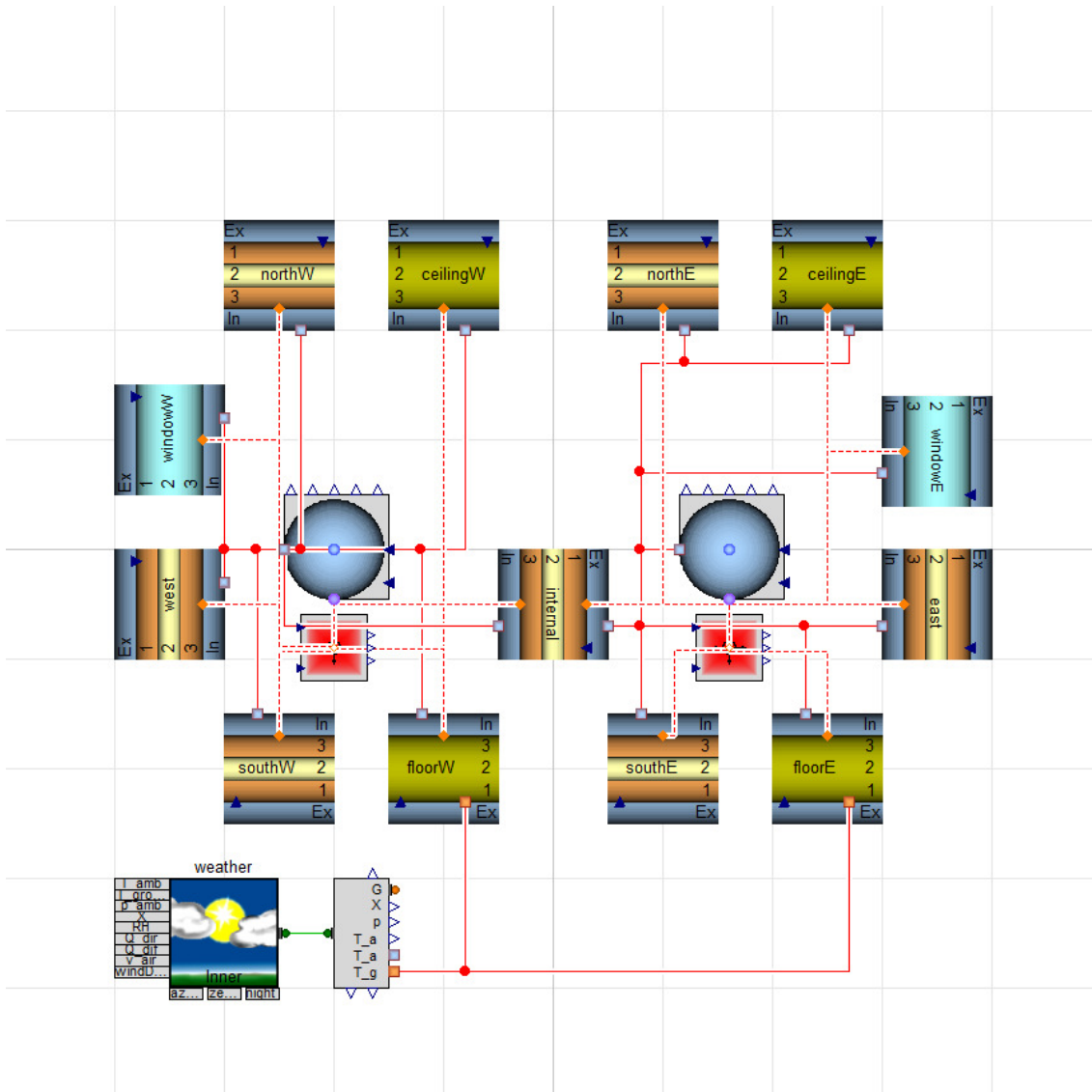

Figure 17: Test model 4 for MoistAir library

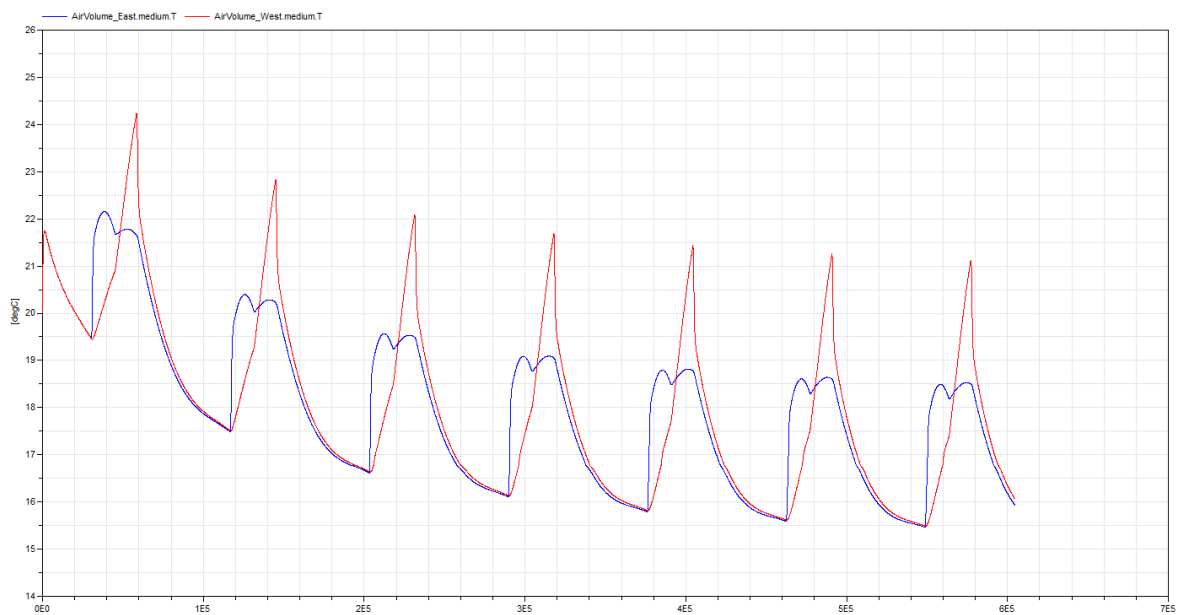

Figure 18: Temperature profile of model 4

3.3 Conclusion

The validation of the implementation of MoistAir shows, that all thermodynamic values are calculated correctly. Moreover, it has been shown, that the library is consistent with respect to obeying all thermodynamic relations like $h = u + pv$.

The above mentioned test models prove, that the new media model for moist air can be used in dynamic simulations. Hence all the requirements are fulfilled.

4 References

4.1 References for R134a

Baehr, H.D. and Tillner-Roth, R.: **Thermodynamic Properties of Environmentally Acceptable Refrigerants - Equations of State and Tables for Ammonia, R22, R134a, R152a, and R123**. Springer-Verlag, Berlin (Germany), 1994.

Klein, McLinden and Laesecke: **An improved extended corresponding states method for estimation of viscosity of pure refrigerants and mixtures**. Int. J. Refrig., Vol. 20, No.3, pp. 208-217, 1997.

McLinden, Klein and Perkins: **An extended corresponding states model for the thermal conductivity of refrigerants and refrigerant mixtures**. Int. J. Refrig., 23 (2000) 43-63.

Okada and Higashi: **Surface tension correlation of HFC-134a and HCFC-123**. Proceedings of the Joint Meeting of IIR Commissions B1, B2, E1, and E2, Padua, Italy, pp. 541-548, 1994.

4.2 References for MoistAir

Lemmon, Jacobsen, Penoncello and Fried: **Thermodynamic Properties of Air and Mixtures of Nitrogen, Argon, and Oxygen From 60 to 2000 K at Pressures to 2000 MPa**. J. Phys. Chem. Ref. Data, Vol. 29, No. 3, 2000.

Lemmon and Jacobsen: **Viscosity and Thermal Conductivity Equations for Nitrogen, Oxygen, Argon, and Air**. International Journal of Thermophysics, Vol. 25, No. 1, January 2004.

Revised Release on the IAPWS Formulation 1995 for the Thermodynamic Properties of Ordinary Water Substance for General and Scientific Use. 2009 International Association for the Properties of Water and Steam.

Revised Release on the IAPWS Industrial Formulation 1997 for the Thermodynamic Properties of Water and Steam. 2007 International Association for the Properties of Water and Steam.

Release on the IAPWS Formulation 2008 for the Viscosity of Ordinary Water Substance. 2008 International Association for the Properties of Water and Steam.

Release on the IAPWS Formulation 2011 for the Thermal Conductivity of Ordinary Water Substance. 2011 International Association for the Properties of Water and Steam.

Revised Release on the Equation of State 2006 for H₂O Ice Ih. 2009 International Association for the Properties of Water and Steam.

Revised Release on the Pressure along the Melting and Sublimation Curves of Ordinary Water Substance. 2011 International Association for the Properties of Water and Steam.

Herrmann, Kretzschmar, Teske, Vogel, Ulbig, Span and Gatley: **Determination of Thermodynamic and Transport Properties of Humid Air for Power-Cycle Calculations**. 2009 PTB, Braunschweig, Germany.

Hellriegel: **Berechnung der thermodynamischen Zustandfunktionen von feuchter Luft in energietechnischen Prozessmodellierungen**. 2001 Diplomarbeit, Zittau.

Thermodynamische Stoffwerte von feuchter Luft und Verbrennungsgasen. 2003 VDI-Richtlinie 4670.

Brandt: **Wärmeübertragung in Dampferzeugern und Wärmetauschern**. 1985 FDBR-Fachbuchreihe, Bd. 2, Vulkan Verlag Essen.

4.3 References for validation

Lemmon, Huber and McLinden: **NIST Standard Reference Database 23: Reference Fluid Thermodynamic and Transport Properties—REFPROP, Version 9.0** (National Institute of Standards and Technology, Standard Reference Data Program, Gaithersburg, MD, 2010).

Kretzschmar, Stöcker, Jähne, Knobloch, Hellriegel, Kleemann and Seibt: **Property Library LibHuAir for Humid Air Calculated as Ideal Mixture of Real Fluids and Add-In FluidEXL for MS Excel**. Zittau/Goerlitz University of Applied Sciences, Department of Technical Thermodynamics, Zittau (2001-2005).